

COLORADO 3

This double garage is 5.75m x 5.1m / 19ft x 16.5ft and is a perfect and secure place to store your vehicles or to use as a workshop. Possibly more of an upmarket barn than a timber garage, the Colorado 3 has an internal space of 28.4 sq m. That's enough for two cars, and quite a bit else besides - from your collection of unused sports equipment to your pet guinea pigs cage - whilst still providing enough room for some workstations at the back to keep tools and equipment on.

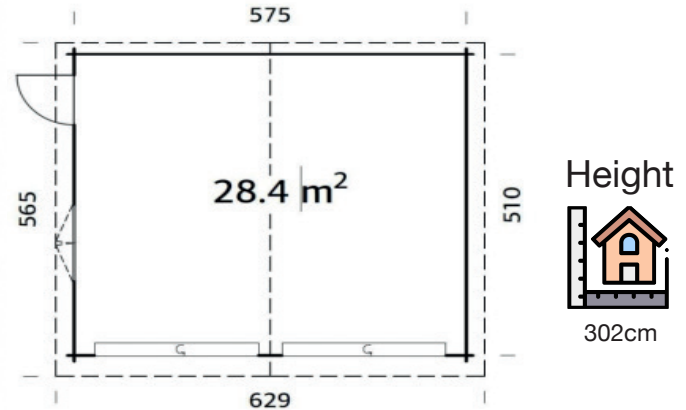

595 x 530cm



44mm



73.5m³



28.4m²



73 x 175,
221 x 188cm



119 x 89cm



N/A



19mm



N/A

FULL SPECIFICATION

CABIN SIZE:	595 x 530cm x 302cm	Wood Type:	Nordic Spruce
WALL THICKNESS:	44mm	Chalet Cut:	Logs (Wind & Rain Protection)
VOLUME:	73.5m ³	Window Type:	Double Glass
AREA:	28.4m ²	Window / Door Feature:	Rubber Seals & Silicone
DOOR OPENING:	73 x 175, 221 x 188cm	Braces:	Wind Braces
WINDOW OPENING:	119 x 89cm	Roof Boards With:	Boards With Tongue & Groove
FLOORS BOARDS:	N/A	Guarantee:	5 Years
ROOF BOARDS:	19mm	Treated Foundation Joists:	No
ROOF OVERHANG:	N/A	IDEAL FOR:	GYM
UNDER PLANNING:	No		

FROM £7,644

FINANCE FROM £73.83PCM

